



Patient & Family Guide
2022

Cardiac Event Recorder (Loop Recorder)



www.nshealth.ca

Cardiac Event Recorder (Loop Recorder)

This guide is for a “King of Hearts” loop recorder.

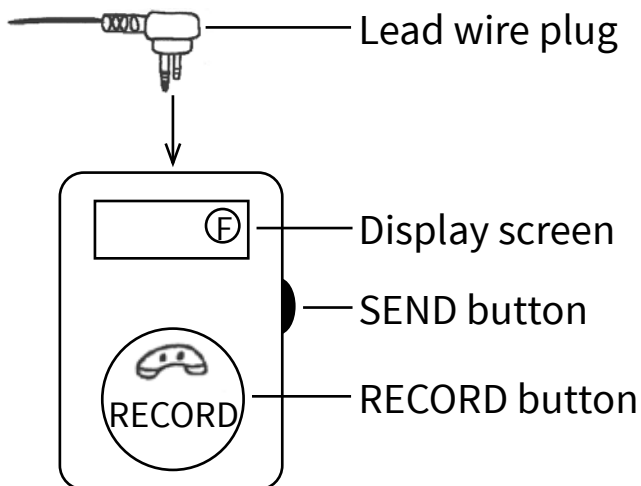

What is a cardiac event recorder?

- A cardiac event recorder (loop recorder) records the electrical activity of your heart. You can use a loop recorder while you are at home and doing your usual activities.
- A cardiac technologist will show you how to use the recorder. They will also answer any questions you have before you take it home.
- The loop recorder will only record your heart activity when you press a button. Start recording when you feel your symptoms starting.

- The information from the recorder can help your doctor diagnose heart symptoms that come and go or only happen sometimes.

How do I use the loop recorder?

Getting ready

- The **electrodes** (small, sticky pads) must be placed firmly on the skin on your chest to get a clear recording.
 - › Wipe your skin clean with an alcohol swab, using the supplies you were given.
 - › Dry your skin with the gauze pads you were given.
- Attach the electrodes to the **lead wires** before placing the electrodes on your chest.
 - › The white lead wire connects to the right electrode.
 - › The black lead wire connects to the left electrode.
- **Place the electrodes** on your chest in the position shown in the diagram on page 3.
 - › Press the electrodes firmly to your skin.
 - › Throw away any electrodes that do not stick.
- **Change the electrodes** every day, or more often if they get loose or are not sticking well.

- After you have placed the electrodes on your chest, put the **plug** from the **lead wires** into the top of the recorder (see diagram on page 1).
- Secure the recorder as told by the technologist.

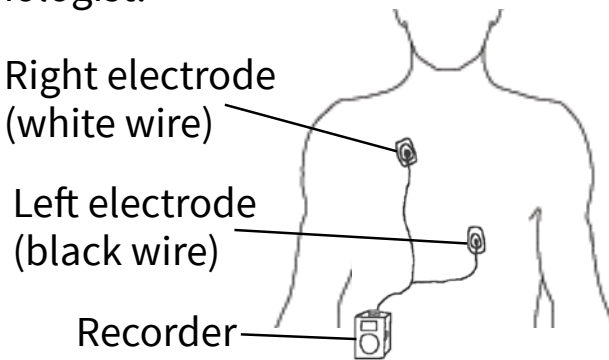

Recording

- Press **RECORD** when you have:
 - › Dizziness
 - › Chest pain
 - › Lightheadedness
 - › Shortness of breath
 - › Palpitations (fast-beating, fluttering, or pounding heart)
- Relax and stay still while the device is recording.
- You will hear a series of 5 tones (beeps). This means the device has stopped recording.

- After recording, you will see an “F” in the display screen. This means the device memory is full and it cannot record any more. **You must transmit (send in) your recording** (see below). The device will keep beeping every few minutes until you transmit your recording.

If you press the RECORD button by accident:

- › You will hear a series of 5 tones and you will see an “F” in the display screen. **You do not need to transmit this recording, but you do need to erase it.**

To erase a recording:

- › Unplug the lead wire from the top of the recorder.
- › Press the **SEND** button on the side of the recorder until you hear a whistling sound.
- › When the whistling sound stops, plug the lead wire back in.

Transmitting

- **You will need a landline phone to transmit. You cannot use a cell phone or cordless landline phone.**
 - › Unplug the lead wire from the top of the recorder.

Remember:

- **Your home phone number is your identification (ID) number.**
- The # symbol on your phone is called the “pound” key.

When you are ready to send in a recording:

Call **902-473-7797** and follow the instructions.

You must state:

1. Your full name
2. The symptoms you had when you recorded
3. Where you were and what you were doing when you recorded

- Put the recorder face-up on a table or flat surface next to the phone.
- Put the mouthpiece (the part you talk into) of the phone over the **RECORD button** of your recorder.
- Press the **SEND** button on the side of the recorder to start the transmission. Hold the **SEND** button until you will hear a whistling sound.
- When the whistling sound stops, plug the lead wire back in.

Replacing the batteries

Check the batteries each time you turn on the recorder. If a battery symbol appears on the display screen, the battery is low. Replace the batteries with 2 AAA batteries (2 triple A batteries).

Can I bathe or shower with the loop recorder?

- You must unplug the lead wire, and take off the recorder and electrodes to bathe or shower.
- You must follow the steps to get ready (on page 2) before putting the electrodes back on your chest.

What if I have problems with the recorder?

If you have questions or concerns about your recorder:

- Call **902-473-2422** and leave a message.
 - › If it is a weekday (Monday to Friday, 8 a.m. to 4 p.m.), a technologist will call you back within 24 hours (1 day).
 - › If it is a weekend or holiday, a technologist will call you as soon as possible on Monday to Friday, 8 a.m. to 4 p.m.

If you are concerned about your symptoms, call your primary health care provider.

How do I return the recorder?

You must return your recorder by:

You cannot place the recorder in the mail. You must return it in person to:

Cardiac Services
3rd floor, Halifax Infirmary
Attention: Holter Lab
QEII Health Sciences Centre
1796 Summer Street
Halifax, NS B3H 3K4

Looking for more health information?

Find this pamphlet and all our patient resources here: <https://library.nshealth.ca/PatientEducation>

Contact your local public library for books, videos, magazines, and other resources.

For more information, go to <http://library.novascotia.ca>

Connect with a registered nurse in Nova Scotia any time: call 811 or visit <https://811.novascotia.ca>

Learn about other programs and services in your community: call 211 or visit <http://ns.211.ca>

Nova Scotia Health promotes a smoke-free, vape-free, and scent-free environment.

Please do not use perfumed products. Thank you!

www.nshealth.ca

Prepared by: Cardiac Services

Illustration by: LifeART Super Anatomy 1 Images, Copyright © 1994, TechPool Studios Corp. USA

Designed by: Nova Scotia Health Library Services

The information in this pamphlet is for informational and educational purposes only.

The information is not intended to be and does not constitute health care or medical advice.

If you have any questions, please ask your health care provider.

WG85-0974 © March 2022 Nova Scotia Health Authority

The information in this pamphlet is to be updated every 3 years or as needed.